



for (1), (2), (3) or (4) F32T8, F25T8
and F17T8 fluorescent lamps

Instant Start, Standard Electronic Ballast "Small Can" Design



Function

Advance's most popular family of high-frequency electronic ballasts delivering optimal energy-savings, proven reliability and quiet, flicker-free operation! Featured here are the 1, 2, 3 and 4 lamp T8 models, in a new **Small Can (SC)** design.

Applications

- General office lighting
- Conference rooms
- Meeting rooms
- Boardrooms
- Executive offices
- New construction and retrofit installations

Design Highlights

- **Instant-Start Circuitry**
 - ✦ Optimizes energy efficiency
 - ✦ Provides low cost advantage versus rapid start designs
- **Light-weight, Low Profile Enclosure**
(Weights 1.6 lbs. - Measures 9.5"L x 1.7"W x 1.18"H)
 - ✦ Promotes flexibility in fixture designs
 - ✦ Facilitates shipping, handling and installation
- **Parallel Lamp Operation**
 - ✦ Keeps fixtures functional should a lamp fail
 - ✦ Quickly identifies the failed lamp for replacement
- **Lamp remote or tandem mounting capable - (up to 20')**
 - ✦ Allows one ballast to operate two fixtures
- **Operates above 40kHz**
 - ✦ Minimizes risk of interference with infrared remote control systems
- **Exceptional Power Quality**
(Power factor >98%, <20 THD)
 - ✦ Delivers maximum system performance
 - ✦ Exceeds recommended utility guidelines for lighting systems
 - ✦ Ensures functional lighting in low temperature applications

Standard Instant Start Ballast Specifications

Section I - Physical Characteristics

- 1.1 The electronic ballast shall be physically interchangeable with standard electromagnetic ballasts and standard electronic ballasts
- 1.2 The electronic ballast shall have a maximum height of 1.18 in. and maximum weight of 1.8 lbs.
- 1.3 The electronic ballast shall be furnished with integral leads, color-coded to ANSI C82.11.

Section II - Performance Requirements

- 2.1 The electronic ballast shall operate from a nominal line voltage of 120 or 277 volts, +/-10%, 60Hz.
- 2.2 The electronic ballast input current shall have Total Harmonic Distortion (THD) of less than 20% when used with primary lamp.
- 2.3 The electronic ballast shall have a Power Factor greater than 98% when used with primary lamp.
- 2.4 The electronic ballast shall withstand a sustained short to ground or open circuit of any output leads.
- 2.5 The electronic ballast shall be Sound Rated A.
- 2.6 The electronic ballast output frequency to the lamps shall be above 40kHz to minimize interference with infrared control systems and eliminate visible flicker.

- 2.7 The electronic ballast shall meet ANSI C82.11, where applicable.
- 2.8 The electronic ballast shall withstand transients specified in ANSI C62.41, Location Category A3.
- 2.9 The electronic ballast shall be CBM certified, where applicable.

Section III - Regulatory Requirements

- 3.1 The electronic ballast shall meet the requirements of the Federal Communications Commission rules and regulations, Title 47 CFR part 18, for Non-Consumer equipment.
- 3.2 The electronic ballast shall comply with all applicable state and federal efficiency standards.
- 3.3 The electronic ballast shall be Underwriters Laboratories (UL) Listed (Class P) and CSA Certified where applicable.

Section IV - Other

- 4.1 The electronic ballast shall not contain Polychlorinated Biphenyl (PCB's).
- 4.2 The electronic ballast shall carry a five-year warranty from the date of manufacture. Warranty shall be valid for a maximum case temperature of 70°C.
- 4.3 The manufacturer shall have a ten-year history of producing electronic ballast for the North American market.
- 4.4 The electronic ballast shall be produced in a factory certified to ISO 9002 Quality System Standards.

Wiring Diagrams

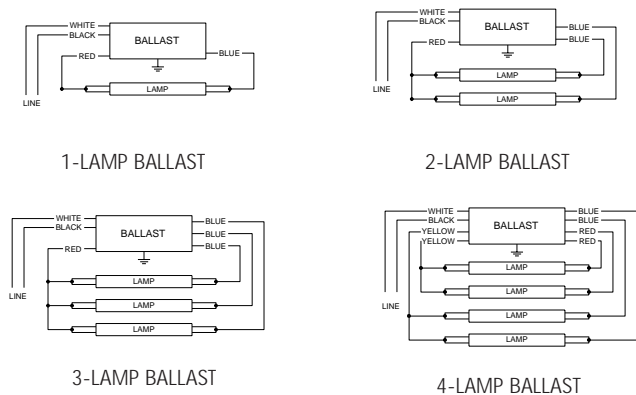

Dimensions

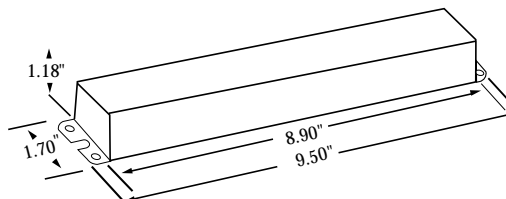

Lamp Data		Min. Starting Temp. (°F/°C)	Input Volts	Catalog Number	Line Current (Amps)	Input Power ANSI (Watts)	Ballast Factor	THD (%)	Power Factor
Number	Watts								
F32T8, FBO31T8, F32T8/U6									
1	32	0/-18	120	REL-1P32-SC	0.27	32	0.92	20	0.98
			277	VEL-1P32-SC	0.12				
			120	REL-2P32-SC	0.34	38			
			277	VEL-2P32-SC	0.15				
2	32	0/-18	120	REL-2P32-SC	0.49	58	0.88	20	0.98
			277	VEL-2P32-SC	0.21				
			120	REL-3P32-SC	0.54	65			
			277	VEL-3P32-SC	0.24				
3	32	0/-18	120	REL-3P32-SC	0.71	85	0.88	20	0.98
			277	VEL-3P32-SC	0.31				
			120	REL-4P32-SC	0.79	94			
			277	VEL-4P32-SC	0.34				
4	32	0/-18	120	REL-4P32-SC	0.94	112	0.88	20	0.98
			277	VEL-4P32-SC	0.41				
F25T8, FBO24T8, F17T8, FBO17T8: Consult Advance Atlas for specifications									

