

LHB04 Linear High Bays

Power Selectable | Colour Selectable | 120-347V

The successor to our best-selling LHB03 Linear High Bays!

Ideal for warehouses, factories, workshops, and more

Energy efficient replacement for traditional fluorescent fixtures and HID high bays



Power Selectable

110W / 130W / 150W

0-10V Dimmable

Complete with 10'
Cord Whip

Colour Selectable
3500K / 4000K / 5000K



Centre Knockout Allows
for Easy Installation of an
Optional Motion Sensor
(sold separately)

Newly Designed,
Shatterproof
Polycarbonate Optics
meet/exceed DLC 5.1
glare standards

Strong Die Cast
Housing
and reduced size for
easy installation

*3 ft Chain and Mounting Hooks Included

TECHNICAL DATA



LIGHT SPECIFICATIONS

Efficacy	132 lm/W
CCT	3500K / 4000K / 5000K
CRI	83
Beam Angle	90°
Dimmable	0-10V
L70 Life	50,000 hrs
Warranty	5-year

LUMEN OUTPUT			
	3500K	4000K	5000K
110W	15437 lm	16275 lm	15960 lm
130W	17780 lm	19155 lm	18551 lm
150W	19745 lm	21483 lm	20790 lm

APPROVALS & LISTINGS

cUL	E482965
DLC Premium	S-5T7PBJ

DIMENSIONAL DRAWINGS (IN)

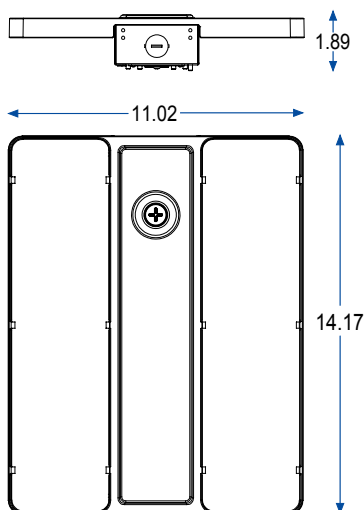

ELECTRICAL

Wattage	110W / 130W / 150W
Voltage	120-347V
Current	1.60A
Surge Protection	6kV
Auxiliary Output	12V
Power Factor	0.9
THD	15%
Operating Temp	-40 to 50°C

CONSTRUCTION

Cord Whip	10'
Housing	Die Cast Aluminum
Lens	Polycarbonate
Finish	Powder Coated
Finish Colour	White
IP Rating	IP20

DIMENSIONS AND WEIGHTS

Fixture Weight	4.2 lbs
Fixture Dimensions	14.17" x 11.02" x 1.89"
Carton Qty	1
Carton Weight	5.95 lbs
Carton Dimensions	15" x 11.8" x 3.4"

ACCESSORIES (Ordered Separately)

Pendant Mount	LHB04-BKT
Surface Mount	LHB04-SK
Microwave Motion Sensor	MS04-MW-TW-DC
Infrared Motion Sensor	MS01-PIR-TW-DC
Remote Control	MS04-RC
Wire Guard	LHB04-WG-SM