

GE  
Lighting

# Evolve™ LED Garage Light

(EG2R)



imagination at work

## Product Features

High quality lighting meets long life and controllability with the Evolve™ LED Garage Light, EG2R. This fixture features an advanced LED optic specifically designed for applications such as parking decks with low mounting heights to provide high uniformity and excellent vertical light distribution with reduced glare, illuminating your parking area with effective security light levels.

Features include programmable motion sensing, step dimming and daylight harvesting. GE's optical approach with reflective optics and prismatic lens provides a low-glare solution ideal for low mounting height garage applications. Additionally, up-lighting is a standard photometric feature in the EG2R, providing a driver-friendly appearance, and eliminating the "cave-effect" that often occurs without up-light.

The Evolve LED Garage Light significantly reduces energy and maintenance expenses over the life of the system with a rated life of L70, 100,000 hrs and is also RoHS compliant, giving you a lead and mercury free lighting solution.

### Applications

- Garage, warehouse, walkway and stairway lighting.

### Housing

- Die-cast aluminum heat sink to maximize heat transfer for electrical components and provide long LED life.



### LED & Optical Assembly

- Evolve™ light engine consisting of reflective technology designed to optimize application efficiency and produce a low-glare lighting solution.
- Utilizes high brightness LEDs, 70 CRI typical at 4000K and 5000K.

### Lumen Maintenance

- Projected L70(10K) > 100,000 at Ta 25C per IES TM-21.

### Ratings

- /c/ listed per UL 1598.
- UL 8750 LED equipment in Lighting Products.
- IP65 rated optical enclosure per ANSI C136.25-2009.
- Vibration rating at 1G (min) on 2 axis, per ANSI C136.31-2010.
- Driver Rated Life  $\geq$ 100,000 hrs for fixture max ambient at or below 40°C.
- Temperature rated at -40° to 50°C ambient.
- Title 24 compliant with occupancy sensor.

-  DLC Listed

Please refer to the DLC QPL website for the latest and most complete information.  
[www.designlights.org/QPL](http://www.designlights.org/QPL)

### Mounting

- Available with seven different mounting options providing a versatile product to meet almost any field installation condition.
  - Mounting options with wet location rating: 04, 05, 06, 11, 20.
  - Mounting options with damp location rating: 01, 02.

### Finish

- Corrosion resistant polyester powder painted, minimum 2.0 mil. thickness.
- Standard colors: Gray & White.
- RAL and custom colors available.

### Electrical

- 120-277 volt.
- System power factor is >90% and THD <20%
- Class "A" Sound rating.
- EMI: Title 47 CFR 15 Class A.
- Integral surge protection exceeds ANSI C136.2-2015 "Basic" (6kV/3kA - 120 Events).
- Dimming:
  - Wired 0-10V continuous dimming. Order with "D" Option.
  - Optional standalone motion sensor dimming.

# Ordering Number Logic

## Evolve™ LED Garage Light (EG2R)



**E G 2 R 0 A 5 P S**    \_ \_    \_ \_    \_ \_ \_ \_    \_

| PROD. ID   | VOLTAGE            | OPTICAL CODE                 | LENS TYPE                               | DRIVE CURRENT       | LED COLOR TEMP                         | MOUNTING ARM   | COLOR                                      | OPTIONS   |
|--|--------------------|------------------------------|---|---------------------|--|--|--|---|
| <b>E</b> = Evolve<br><b>G</b> = Garage<br><b>2</b> = Housing<br><b>R</b> = Round | <b>0</b> = 120-277 | <b>A5</b> = 57W, 5000 Lumens | <b>P</b> = Prismatic Polycarbonate Lens | <b>S</b> = Standard | <b>50</b> = 5000K<br><b>40</b> = 4000K | <b>01</b> = Primary Electric Disconnect with MPM-C*<br><b>02</b> = Primary Electric Disconnect with MPM-3PR*<br><b>04</b> = Primary Electric Disconnect with MPM-3PRW<br><b>05</b> = Primary Electric Disconnect with MPM-3PRTFW<br><b>06</b> = Primary Electric Disconnect with MPM-WW<br><b>11</b> = 3/4" Rigid Pendant<br><b>20</b> = Surface mounting with slide on wiring box<br>* Damp location rated only | <b>GRAY</b> = Gray<br><b>WHITE</b> = White | <b>D</b> = Dimming*<br><b>H</b> = Motion Sensor<br>* D option required for External Dimming (Option H not needed with Option D) |

| PHOTOMETRIC TYPE | OPTICAL CODE | TYPICAL INITIAL LUMENS |       | TYPICAL SYSTEM WATTAGE | IES FILE NUMBER          |                          |
|------------------|--------------|------------------------|-------|------------------------|--------------------------|--------------------------|
|                  |              | 4000K                  | 5000K | 120-277V               | 4000K                    | 5000K                    |
| Type V Symmetric | A5           | 5,000                  | 5,000 | 57                     | EG2R_A5PS40_120-277V.IES | EG2R_A5PS50_120-277V.IES |

# Photometrics

## Evolve™ LED Garage Light (EG2R)

EG2R Type V – Symmetric (A5)  
5,000 Lumens, 5000K (EG2R\_A5PS50\_-120-277V.IES)

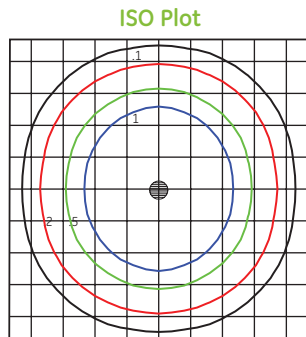

Grid Distance in Units of Mounting Height at 10' Initial Footcandle Values at Grade

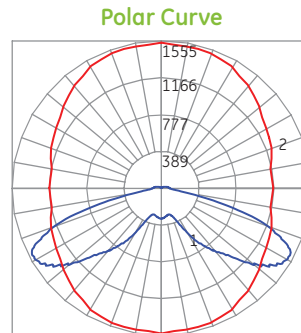

— Vertical plane through horizontal angle of maximum candlepower at 90°  
 — Horizontal cone through vertical angle of maximum candlepower at 62.5°

## H-Motion Sensing Option:

- Recommended for lower mounting heights between 8-15 ft, this sensor provides excellent pedestrian coverage of greater than 2x the mounting height.
  - In a garage application, 360° of coverage is achievable, allowing the sensor detection to closely match the lighting distribution of a typical garage.
  - Comes standard with 50% dimmed light output with no occupancy, and full power at occupancy.
  - Comes standard with a 5 minute occupancy time delay and a 5 minute ramp-down to the 50% dimmed level.
- \* Standard options may be reprogrammed in the field. Contact manufacturer for reprogramming instructions.*

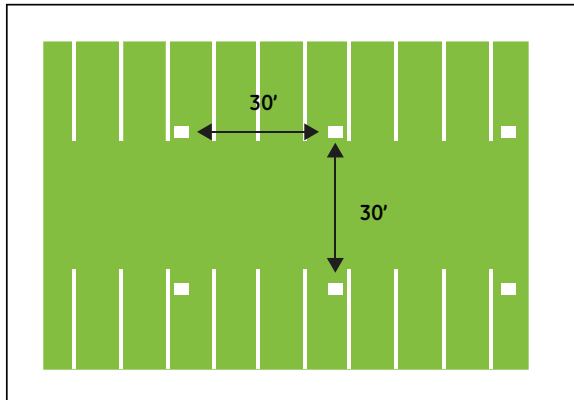
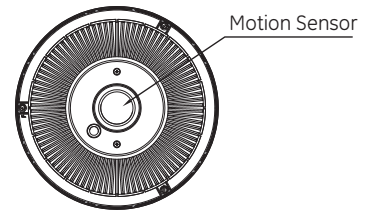

In a typical parking garage application with a mounting height of 10 ft, the sensor's coverage for walking motion extends out (30 ft.)

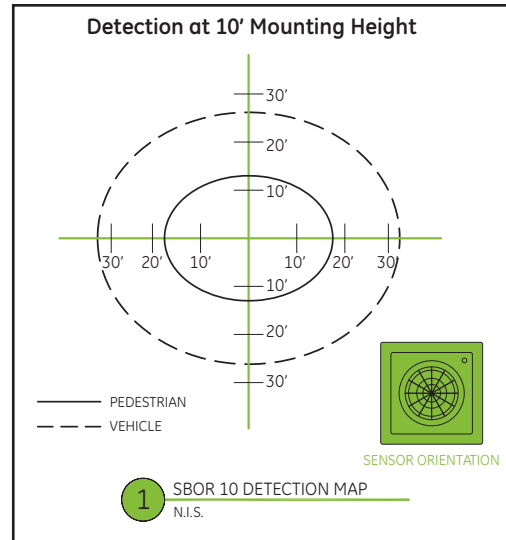

## Product Dimensions

### Garage with Motion Sensor

No major dimensional differences between SKUs with motion sensor and without.

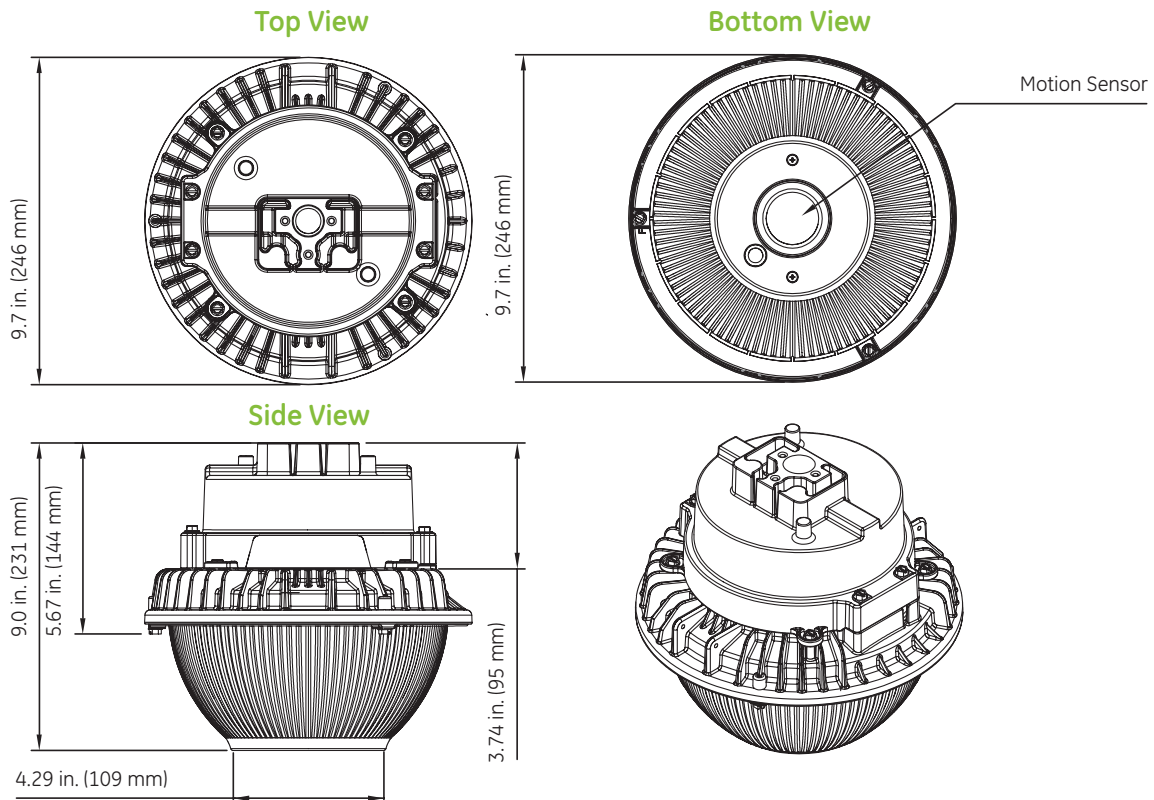

# Product Dimensions

## Mounting Option Code: 01, 20

Primary Electric Disconnect w/MPM-c (01)  
Surface Mounting w/Slide on wiring Box (20)

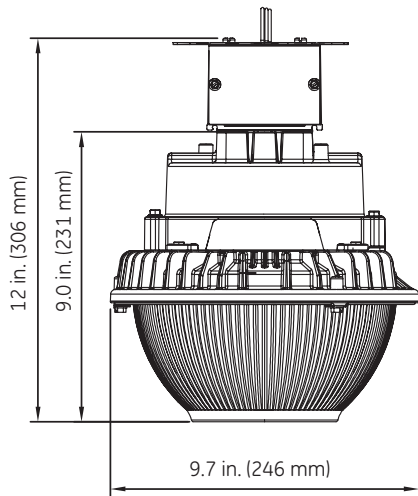

## Mounting Option Code: 02, 04

Primary Electric Disconnect with MPM-3PR (02)  
Primary Electric Disconnect with MPM-3PRW (04)

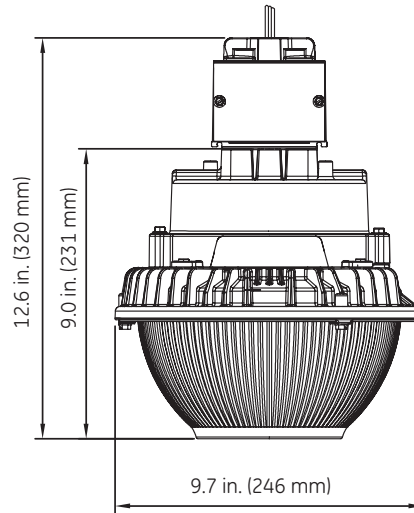

## Mounting Option Code: 05

Primary Electric Disconnect w/MPM-3PRTFW (05)

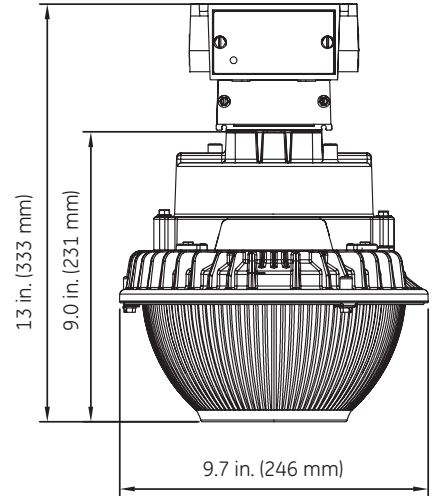

## Mounting Option Code: 06

Primary Electric Disconnect w/MPM-WW (06)

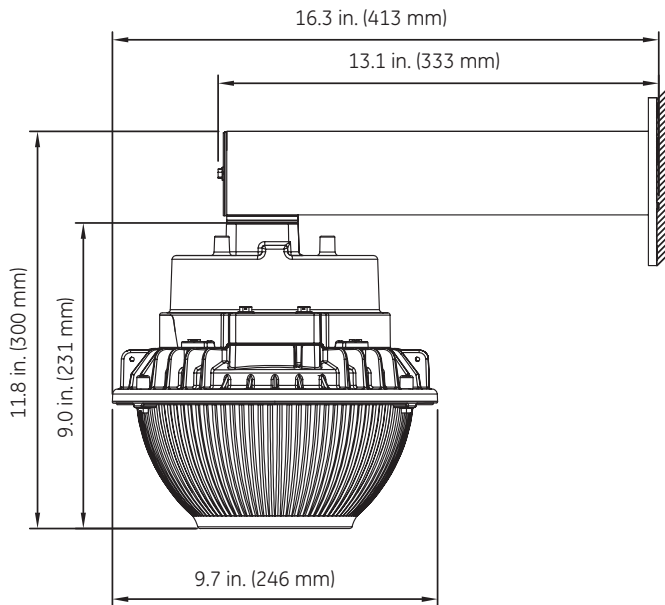

## Mounting Option Code: 11

3/4" Rigid Pendant (standard) (11)

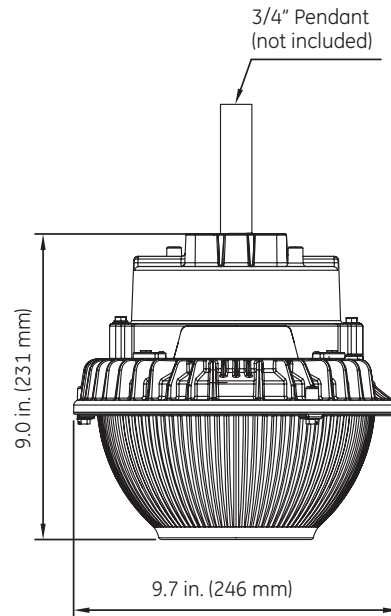

### DATA

- Approximate Net Weight 8-10 lbs



[www.gelighting.com](http://www.gelighting.com)

GE and the GE Monogram are trademarks of the General Electric Company. All other trademarks are the property of their respective owners. Information provided is subject to change without notice. All values are design or typical values when measured under laboratory conditions. GE Lighting is a business of the General Electric Company.  
© 2016 GE.

OLP3084 (Rev 04/03/16)